

New

Tecpacking 2021

Product introduction

tecpacking

| Contents



01 Machine Display



02 Application



03 Sample Bag



04 Specifications



05 characters



06 Weighing System



07 Component List



08 Layout Dimensions

Machine Display



Application

Suitable for candy, hard nut, raisin, peanut, melon seeds, chips, chocolate, biscuit and other big grains or irregular shape products

Automatic feeding, sealing to the ready bag(zipper or no-zipper type)



Specifications-TP-L200/250

Model	TP-L200 / 250
Packing speed	16-50 bags/min(Depends on packing material & bag type)
Packing bag size	Bag Width : 200L 80-200 / 250L 110-250mm Bag Length : 100-350mm
Packing weight	30-3000 kg (General Range)
Air consumption	$\leq 0.6\text{m}^3/\text{min}$
Voltage	380V
Total power	2.3 kw
Dimensions	L4500 * W2820 * H3700mm
Gross Weight	2600kg (Whole set)
Precision	$\leq \pm 1\%$

Operation Procedure

- 1. Bag-Giving
- 2. Coding / Zipper Opening
- 3. Filling A
- 4. Filling B
- 5. Heat sealing A
- 6. Heat sealing B
- Forming & Output

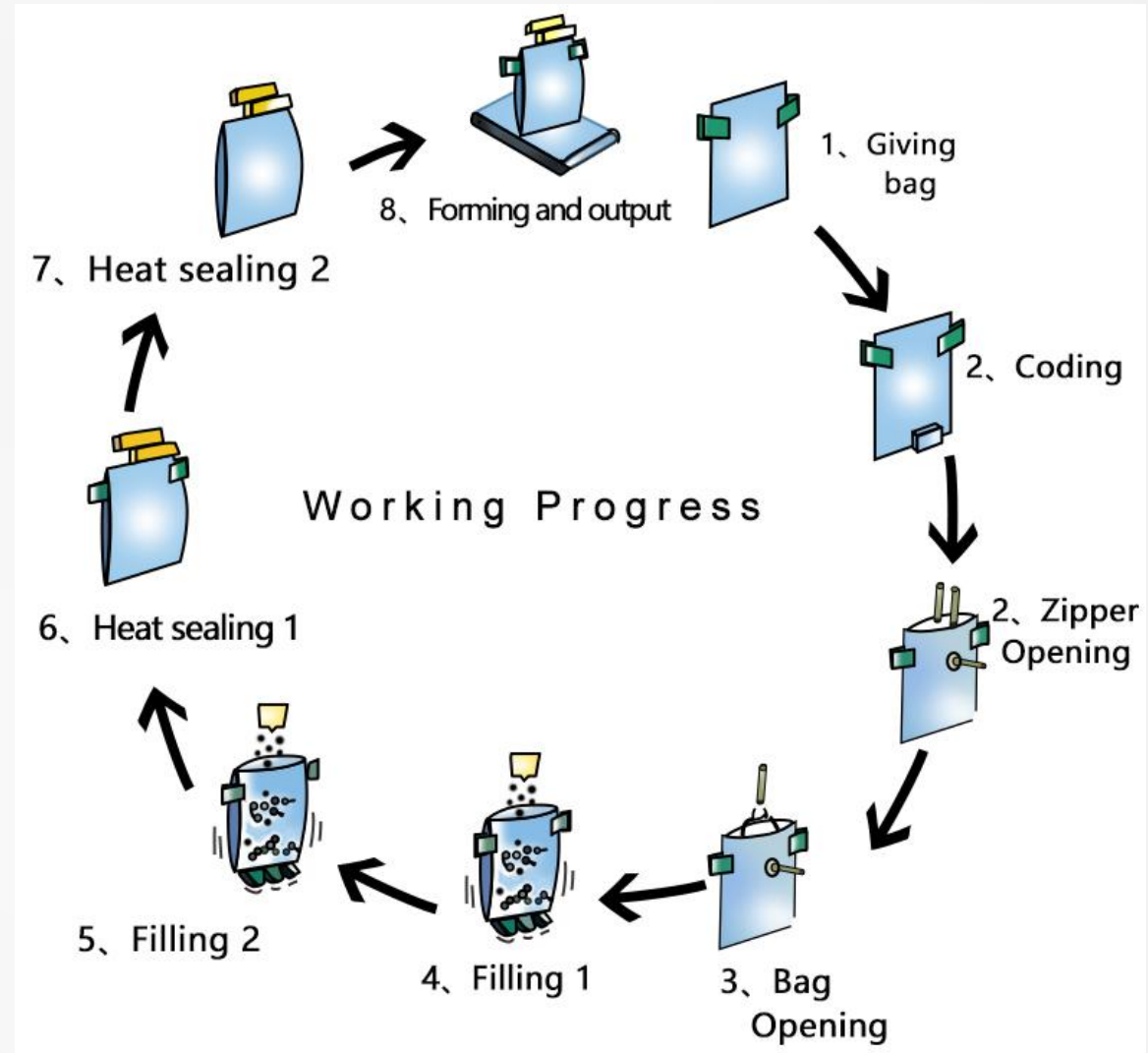

A

Rotary working platform

Fully automatic
High Speed Running
Save Space

**B**

Simens PLC Control System

Intelligent control System :
All the clampers can be adjusted the width
via PLC system, very convenient.

C

Bag Sink

Customerizeable bag-giving type
Easy to adjust for bags with different size





D Accurate filling system

With anti-reflow valve, avoid reflowing
With empty bag detection, will not fill-in when no bag coming.

E Dual Sealing Station

According to your expected sealing effect
To custom-made sealing port.



F Output Conveyor

From bag-given to finished output, all work in one machine.
Conveyor type can be customized according to your request too.





SIMENS PLC CONTROL SYSTEM

Intelligent control System :
All the clampers can be adjusted the width via PLC system, very convenient.

AUTOMATIC ADJUSTMENT STATION

Wide, automatic adjust the bag at the same time, section, the precision is higher



ACCURATE MEASUREMENT AND SMALL ERROR



Weighing System



Character:
10/14 heads multi-heads
weigher with German HBM
loadcell, full stainless steel
for the touching part, simple
operation, and with setting
storage.

Component Of Main Unit

Touch screen	Siemens	Germany
PLC	Siemens	Germany
Inverter	Siemens	Germany
Magnetic valve	Festo	Germany
Coder	Omron	Japan
Main motor	Qiang zhu	China
Blow air valve	SMC	Japan
Stand cylinder	Festo	Germany
Divider	Fukesen	China

Layout Dimensions

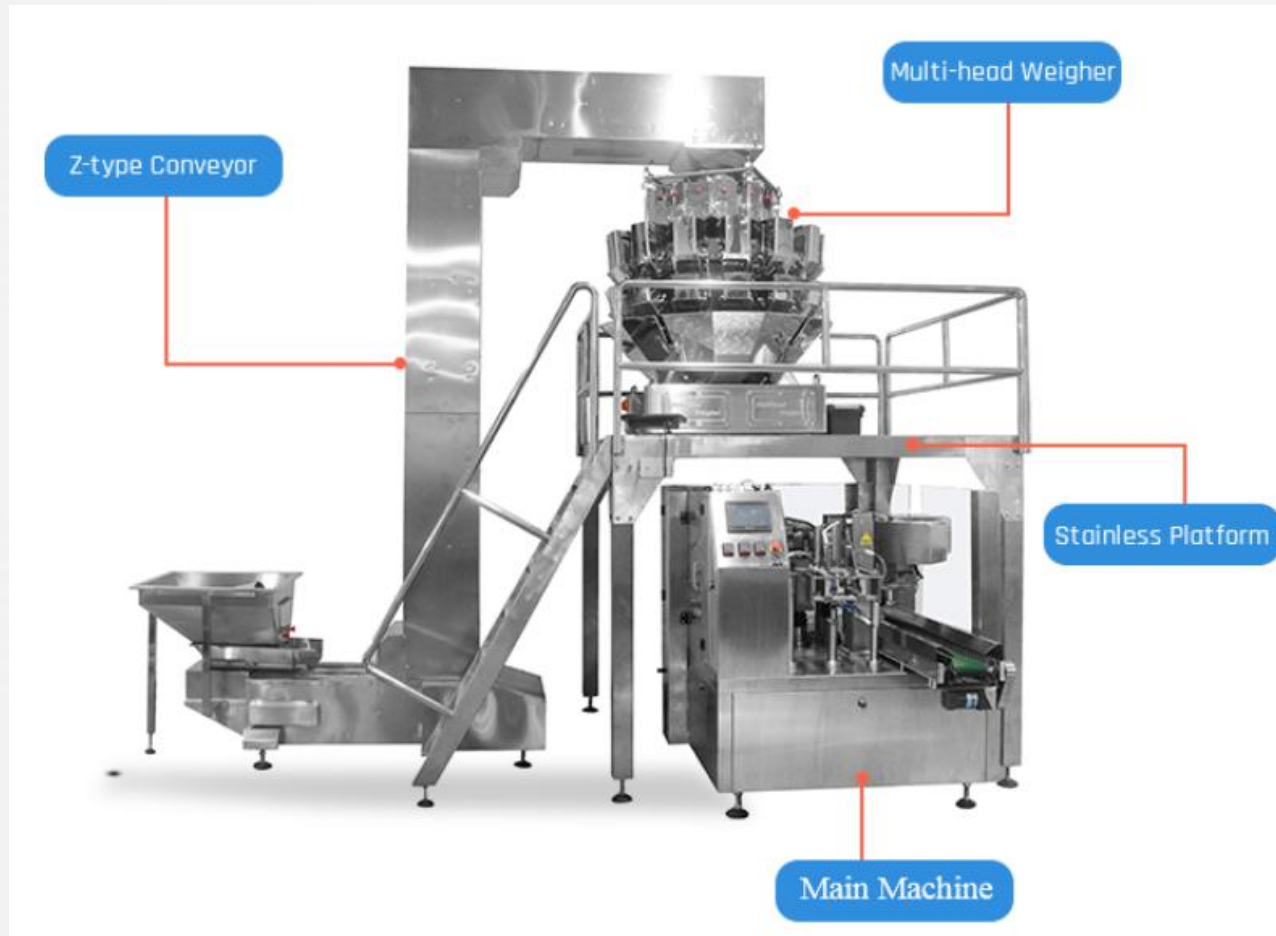

Overall dimension :

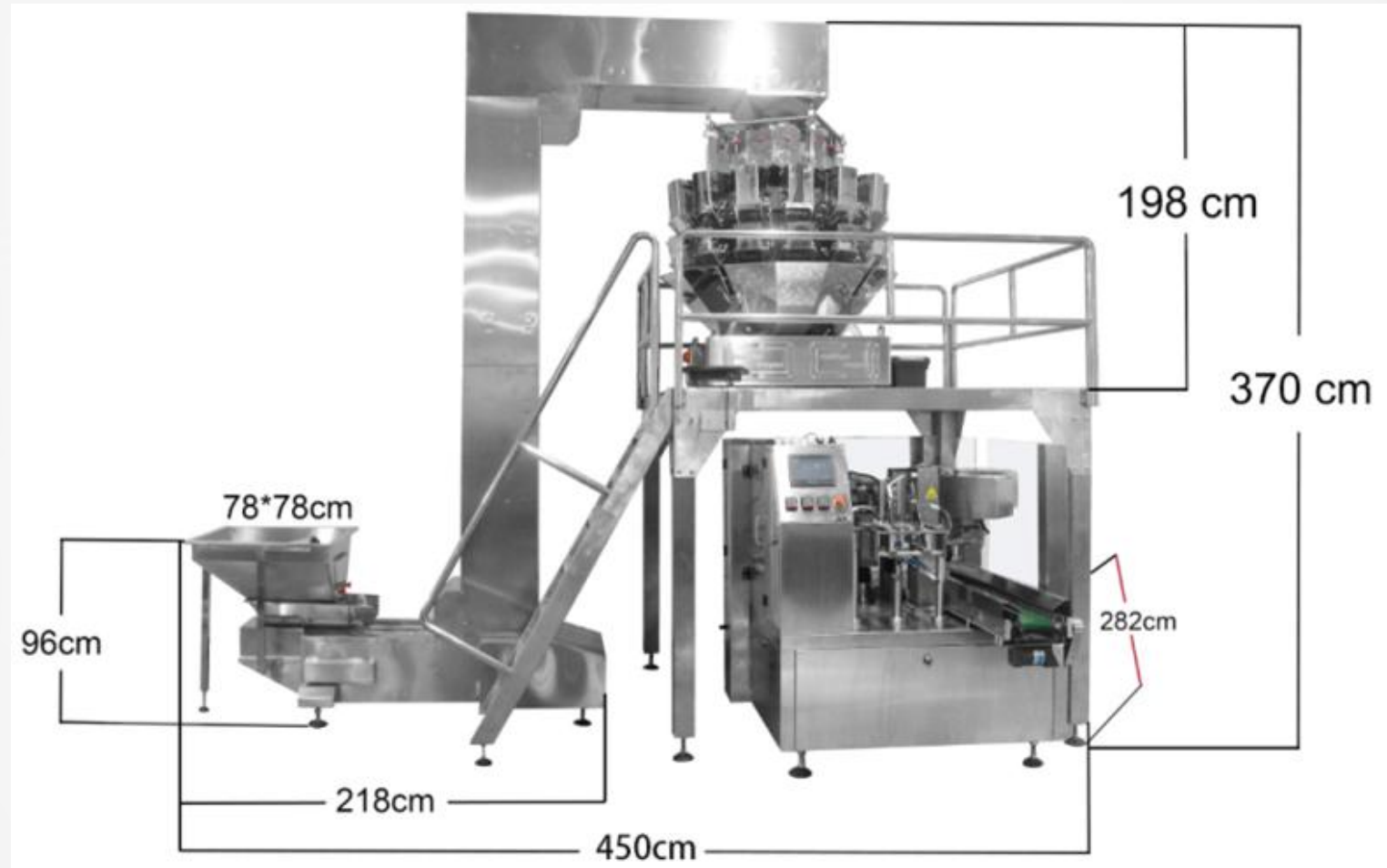

After-Sales Service 务

1. Warranty : One years from the date of shipment

2. 24 hours online services provide technical support

3. Life-long technical support accessories service

The logo consists of the letters 'A7' in a bold, white, sans-serif font, centered within a solid black square. The background of the entire image is a low-angle, upward-looking view of modern glass skyscrapers with a blue tint, creating a sense of height and architectural complexity.

A7

GROUP

WhatsApp\Viber\Telegram

+7 910 729 73 63