



**Tecpacking**®

## Pyramid Tea Bag Machine – TP-P100

**Tecpacking** is a packing machinery engineering and packing material company with many years of experience.

Every machine supplied by Tecpacking has been thoroughly scrutinized with exceptional quality control standards and exquisite workmanship.

Now we would like to introduce our newest machine – **TP100**.

**TP-P100** has been designed to deliver maximum quality tea bags, giving you the freedom to adjust the shape and size.

Suitable for packaging all kinds of flower tea, fruit tea, herbal tea.

Upgraded performance and usability with higher speed and no waste of material.



# Safety



According to European standard production, all electrical parts are grounded to prevent electricity danger, electrical cabinet waterproof grade IP54, all parts of the machine is affixed with standard safety production sign.



The machine can be stopped by a safety relay when the safety circuit is out of order, the machine can not be started again, which can guarantee the safety of the operator and the machine.



When the safety door is opening, the machine automatically stop, cylinder pressure relief: Emergency Stop the machine, the horizontal the sealing system automatically relieve pressure, to avoid accidents.

# Smart and easy

A key to control the machine, all functions automatically start, automatically identify the film tagged or not tag.

The machine does not work for more than 10 seconds, and the ultrasonic sealing system shuts off automatically.

When the failure occurs, the PLC automatically shows the part of the failure. After adjusting the machine, press the trouble-clearing key and the machine automatically resets to continue working Production data can be pre-set.

Can set up shift production.

Adjustable speed.

Erase all content and settings.



# Characteristics

Packing speed is **90-100bags/min** which is **80% more efficient** than other machines.

- It adopts a special sensor with high precision and high standard resolution.
- Ex-factory parameters set recovery function, support multi-segment weight calibration.
- When the material is short of, it can be stopped automatically to make the weighing more stable.
- Storage of 100 sets of parameters to achieve a variety of material requirements, help menu, easy to learn to use.
- The amplitude of each line can be adjusted independently in operation to make feeding more even.
- A variety of languages available, easy to operate, suitable for the global market.
- Ultra-small 0.3 L hopper, adopt ultra-low vibration design, run more smoothly, weighing accuracy is higher.
- The new double parallel line vibration machine vibrates less, the side drive type aluminum box reading is more.
- Weighing-type material detection, accurate control filling time, material thickness, ensure weighing accuracy.
- Special v-shaped vibrating plate, small weight weighing design, ensure filling uniformity and weighing accuracy.
- The integral case and center seat increase the strength of the machine, making the hopper stable for a shorter time.





# High speed and stability

Packing speed is **90-100bags/min** which is **80% more efficient** than other machines.

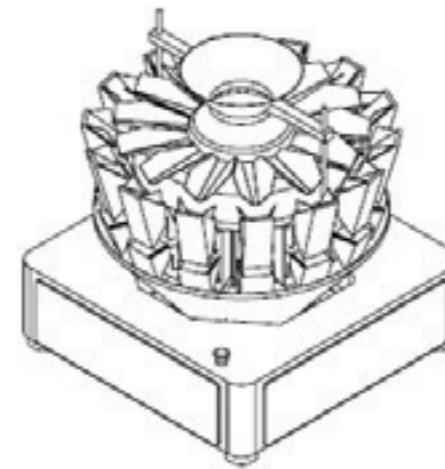

Multi heads (14) weigher with German HBM loadcell, full stainless steel for the touching part, simple operation, and with setting storage.

Easy to set, accuracy 0.1 g.

High accuracy for different tea leaves and herbs.

Ex-factory parameters set recovery function, support multi-segment weight calibration.

Ultra-small 0.3 L hopper, adopt ultra-low vibration design, run more smoothly, weighing accuracy is higher.

Weighing-type material detection. Accurate control filling time, material thickness, ensure weighing accuracy.

Special v-shaped vibrating plate, ensure filling uniformity and weighing accuracy.

The integral case and center seat increase the strength of the machine.



# Touch panel

Touch screen function gives you full control, safety and helps you organize easier.

## Examples:

### Alarm

**“Emergency Stop”** - Alarm and stop when the emergency stop button is pressed.

**“Safety Relay”** - The safety chain is open, and the safety relay does not output a safety normal signal to the PLC.

**“No Tag”** - Alarm and stop when the tag is missing.

**“Production Statistics”** - Jump to the production statistics interface.

**“Auto Run”** - Click to start autorun

**“Progress”** - Progress bar showing progress per package when running automatically

### Manual operating settings

**“Manual Run”** - Allows manual operation after clicking.

And many more.

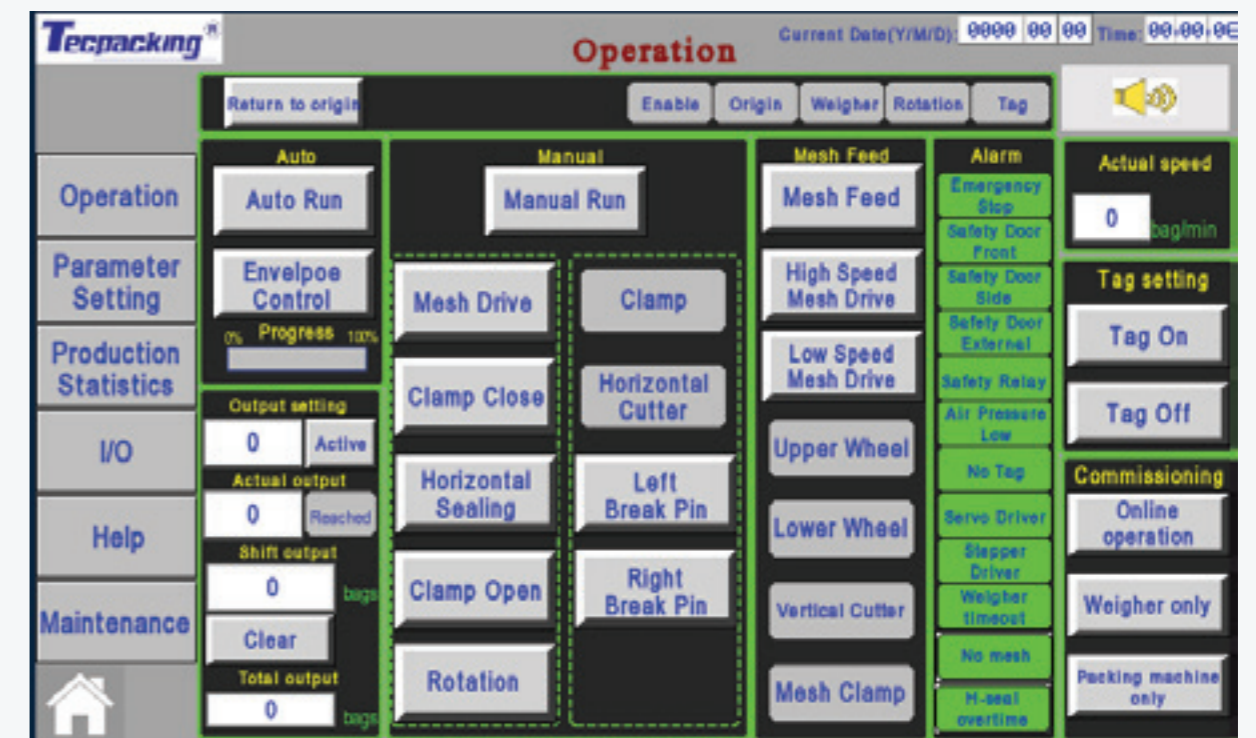

Touch screen operating interface.



# Components

Name	Brand	Country of Origin
PLC	SIMENS S7-1200	Germany
Proximity switch	OMRON	Japan
Photocell	Panasonic	Japan
Servo driver	Delta	Taiwan, China
Servo motor	Delta	Taiwan, China
Stepper motor	MOONS'	China
Stepper driver	MOONS'	China
Circuit breaker	ABB	Switzerland
Button	ABB	Switzerland
Relay	ABB	Switzerland
Photocoupler	Weidmuller	Germany
Main switch	Schneider	France
Limit switch	OMRON	Japan
Door safety switch	OMRON	Japan
Touch panel	Kinco	China
Solenoid valve	SMC	Japan
Cylinder	SMC	Japan
Power supply	MEAN WELL/ OMRON	Germany/Japan



# Components

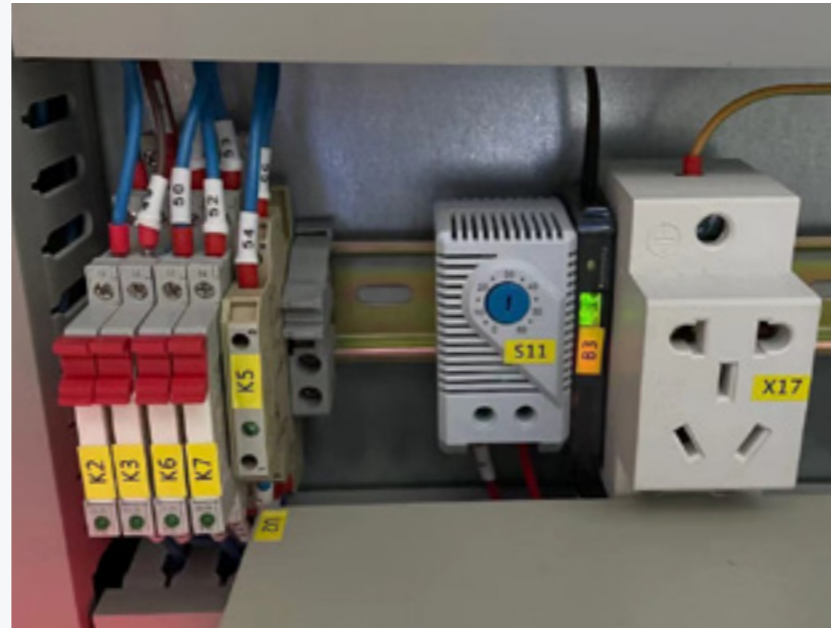

Smart temperature controlling for the electronic box.

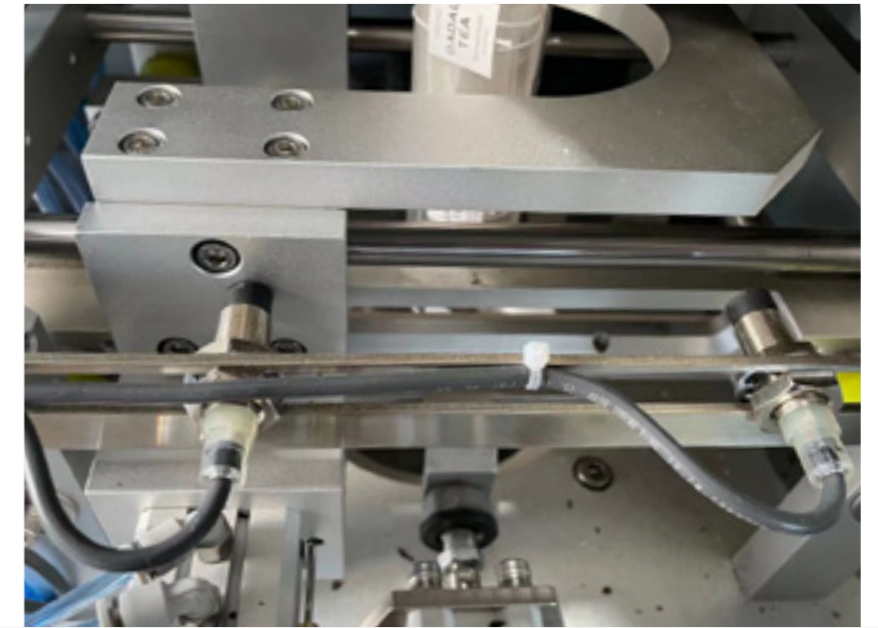

Accurate time control for the horizontal sealing.

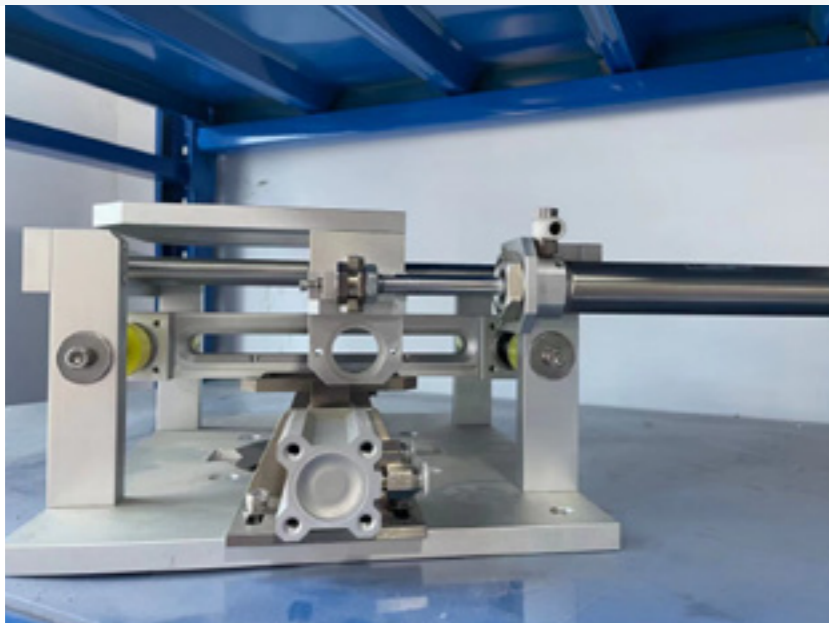

Clean and perfectly finished turntable.

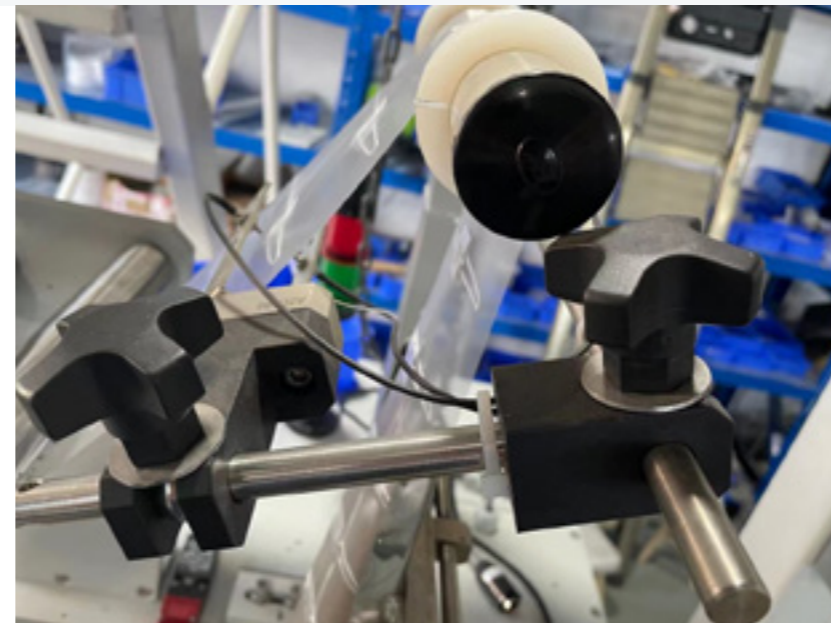

Flexible photocell adjusting frame.



Quality air control part with clean arrangement.



# Components



Advanced Siemens PLC

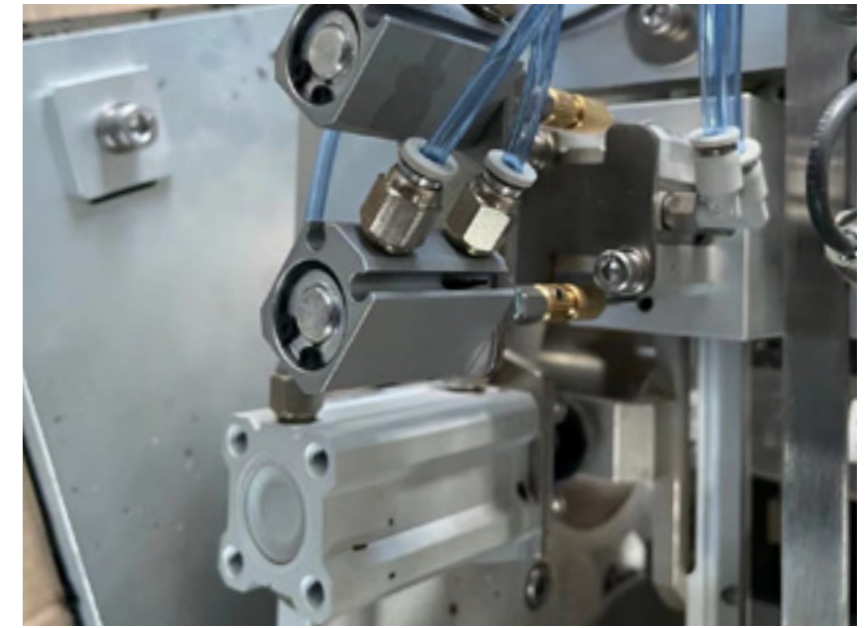

Unique bag separating system.



All main parts with serial number.



Convenient air pressure adjusting for some function.



# Layout dimensions

Overall dimension: L1844x W2900 x H2862 (mm)

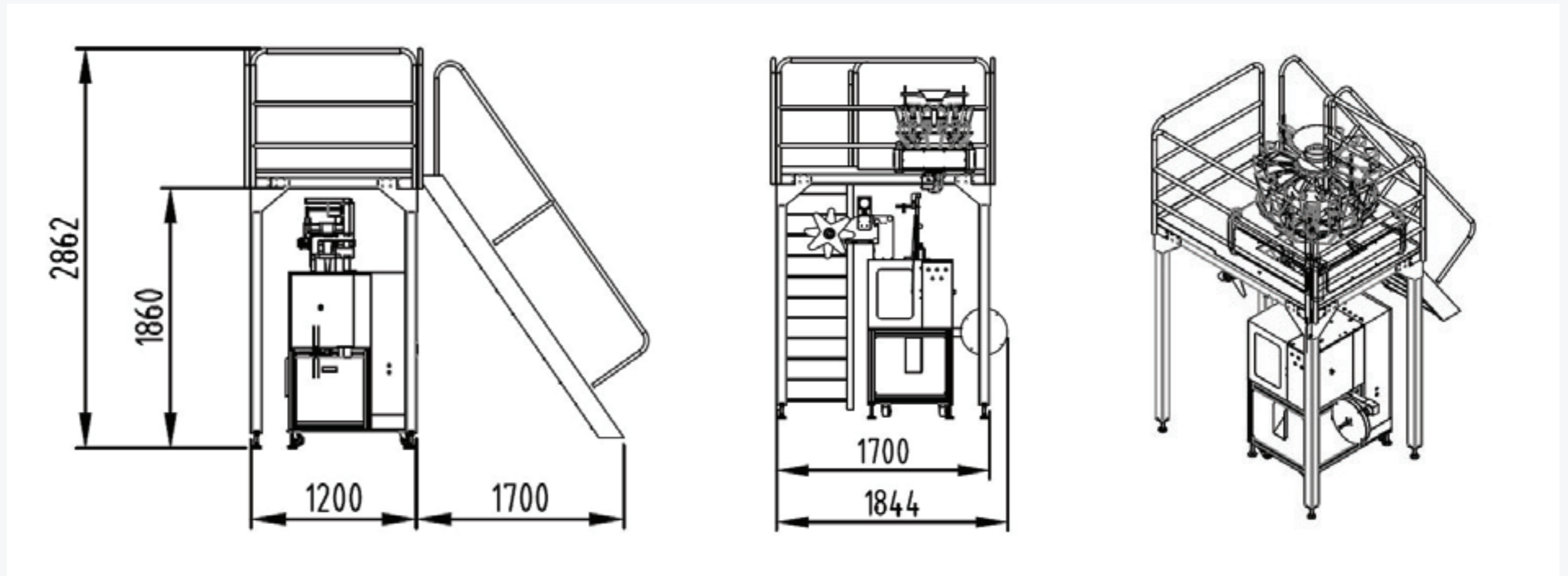

Note: The size may change according to the future pan or customer demands.



# Professional technical support

A clear and professional electric cable diagram enables operators and engineers to fully understand how the machine works.

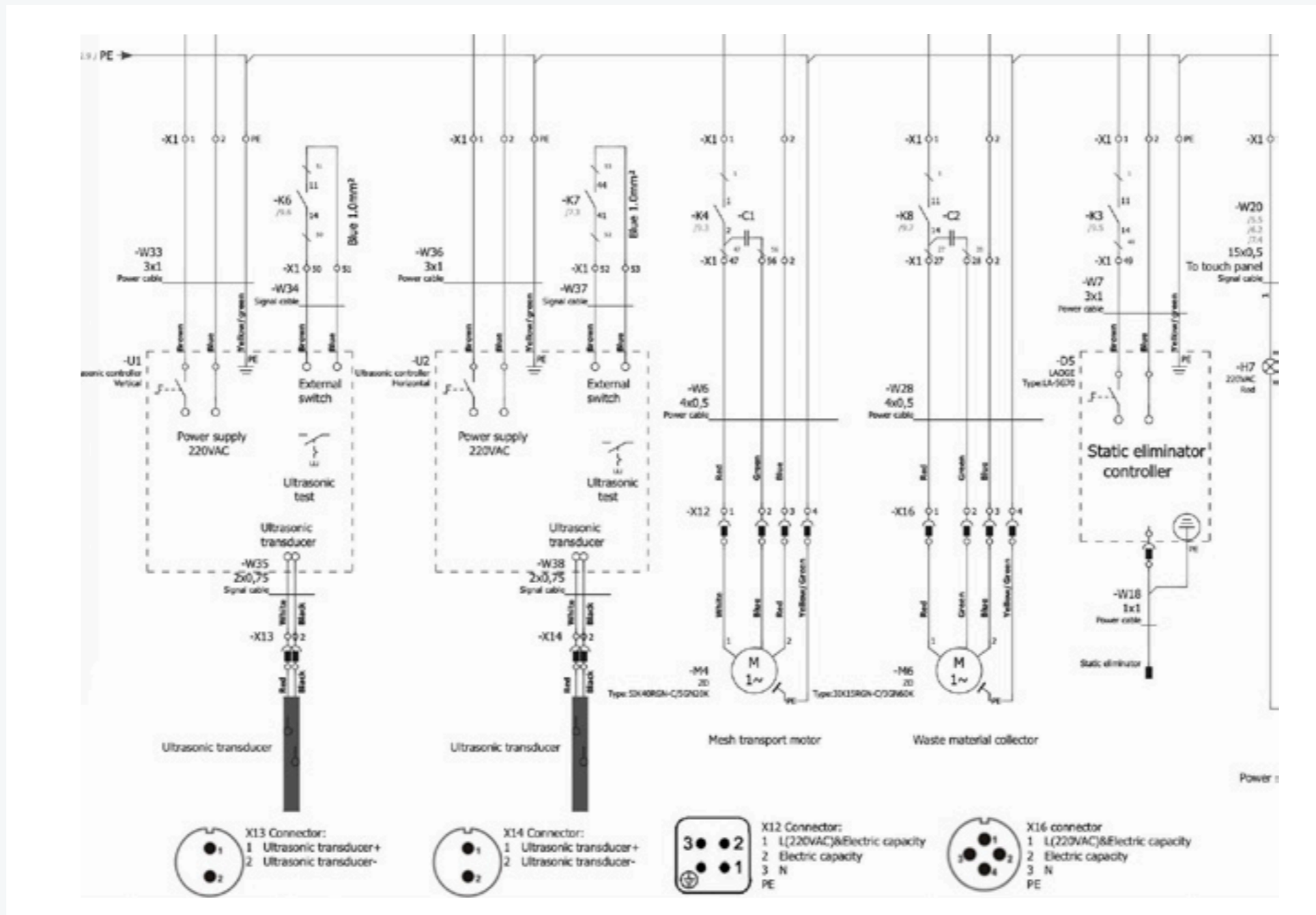

# Tea bag types

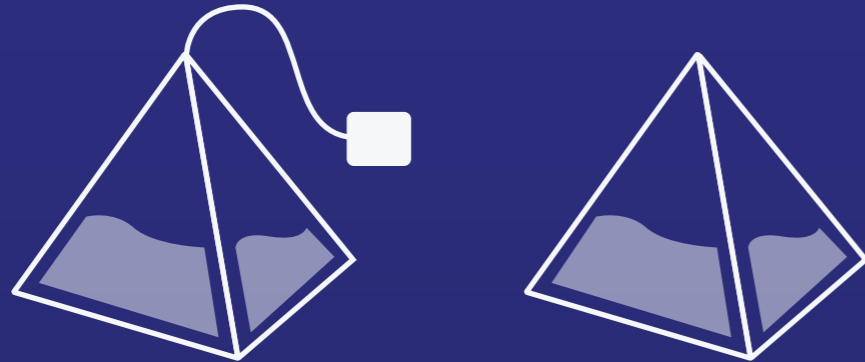

Pyramid tea bag **with and without** a tag.  
Size varies between **50 to 80mm**.

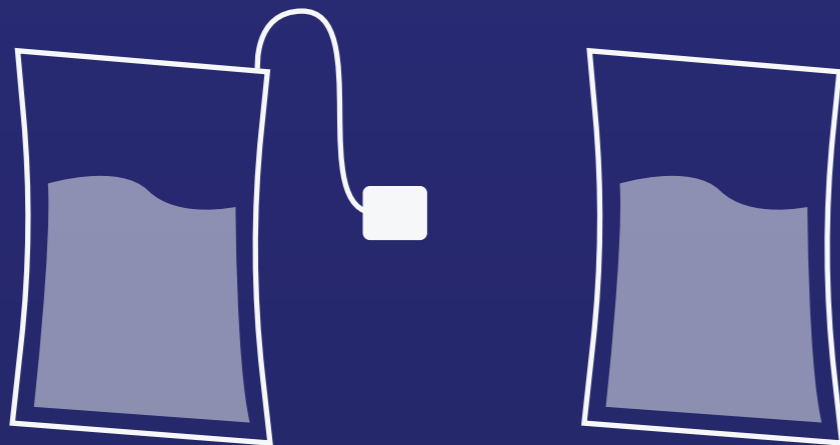

Rectangle tea bag **with and without** a tag.  
The rectangular tea bag maximum size is **160 x 100mm**.



Suitable for big butterfly tag.

We are prominent players in the tea and coffee packaging machinery industry, specialized in conventional and biodegradable pyramid tea bag packing technology and filter materials.

We believe that technology should positively affect people and we are constantly working towards that.

Combining our passion for tea and coffee with engineering and technology knowledge, we emphasize providing environmentally friendly solutions.



# Tea bag types

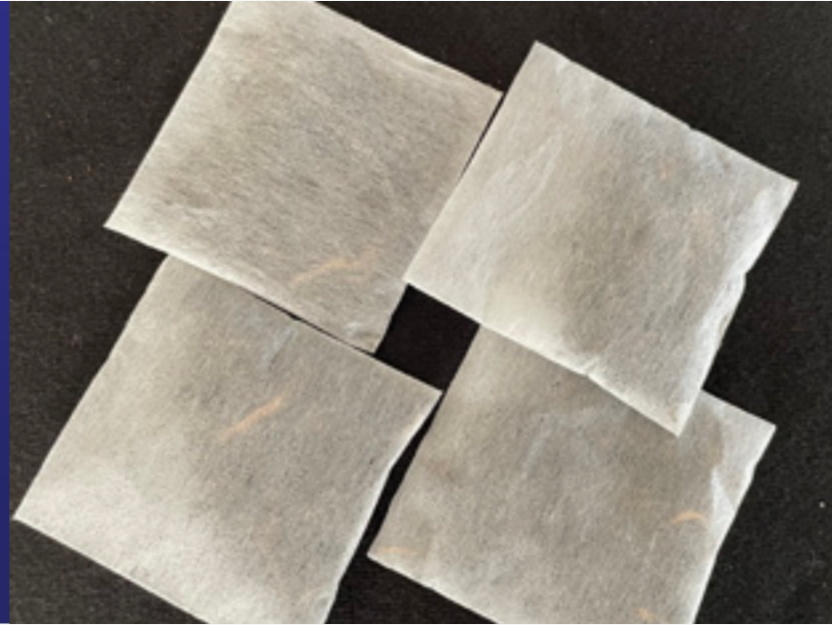

# Packing material

**Compatibility: Nylon, PET, Non-Woven Fabric, PLA etc.  
(ultrasonic sealing filter/mesh)**

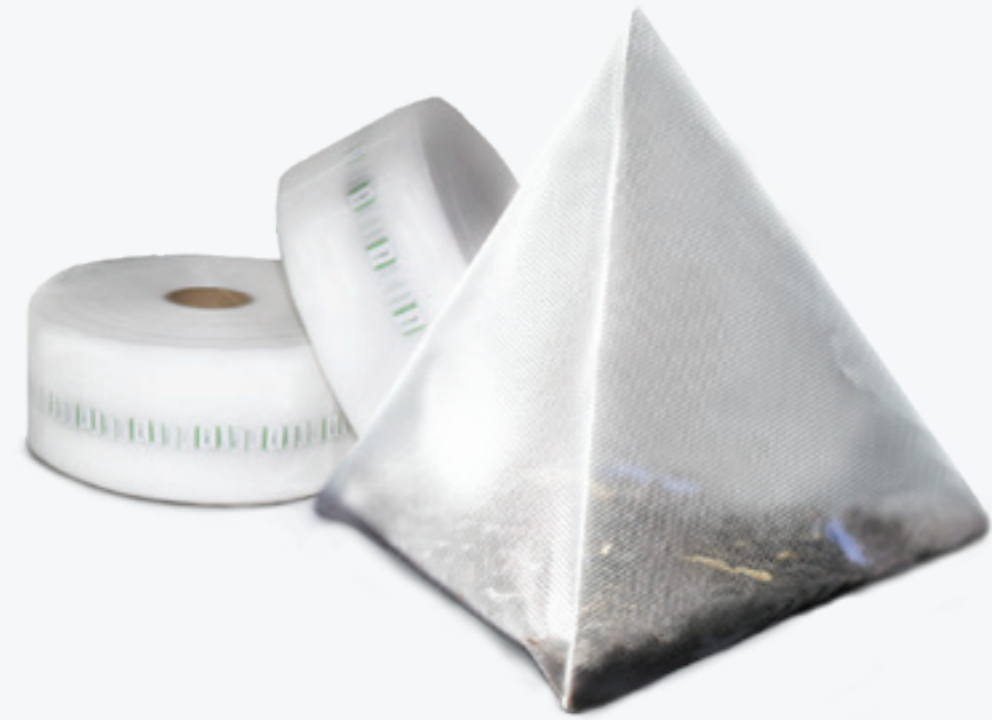

## We can help

We can supply the material you need, with and without tags.

Name	Transparent	Biodegradable	Sealing	Transparent
PLA Mesh	YES	YES	Ultrasonic	Polylactic Acid
Nylon Mesh	YES	NO	Ultrasonic	Polyamide
Non-Wove (PLA)	NO	YES	Ultrasonic	Polylactic Acid
PET Mesh	YES	NO	Ultrasonic	PET

We produce and pack the material **according to Regulation (EC) No 1935/2004 of the European Parliament** and of the Council of 27 October 2004 - on materials and articles intended to come into contact with food and repealing Directives 80/590/EEC and 89/109/EEC.



**Contact us  
for more details.**



# Packing material

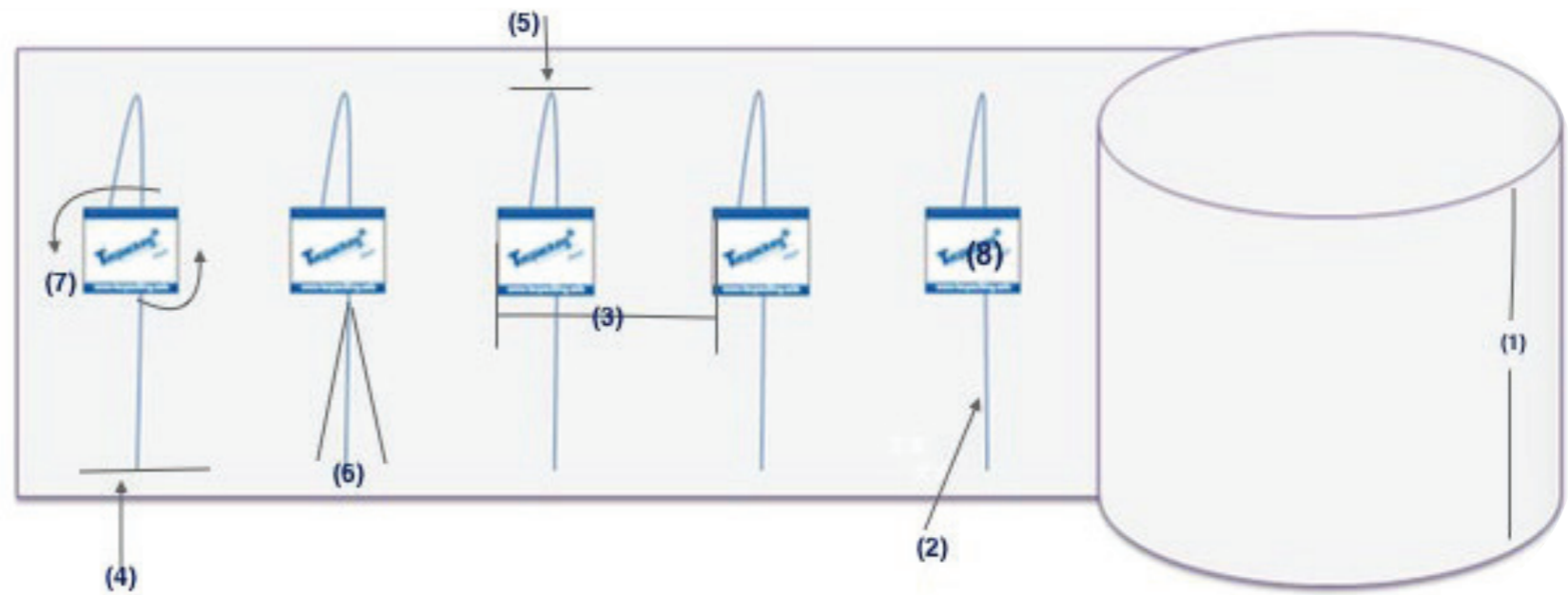

## Specifications

Unit (mm)	(1) Width	(2) Thread length	(3) Tag distance	(4) Distance to edge	(5) Distance to edge	(6) Spreading	(7) Position (degree)	(8) Tag size
<b>Standard</b>	120	110 - 120	50	10	10	2	± 20°	20x20
	140	175	5	12	15	2	± 20°	20x20
	160	175	65	20	26	2	± 20°	20x20
	180	175	72	30	36	2	± 20°	20x20
<b>Tolerance</b>	± 3	± 2	± 2	± 1.5	± 2	± 1.5		± 2

## Tags

More creativity with the new tagging shape.

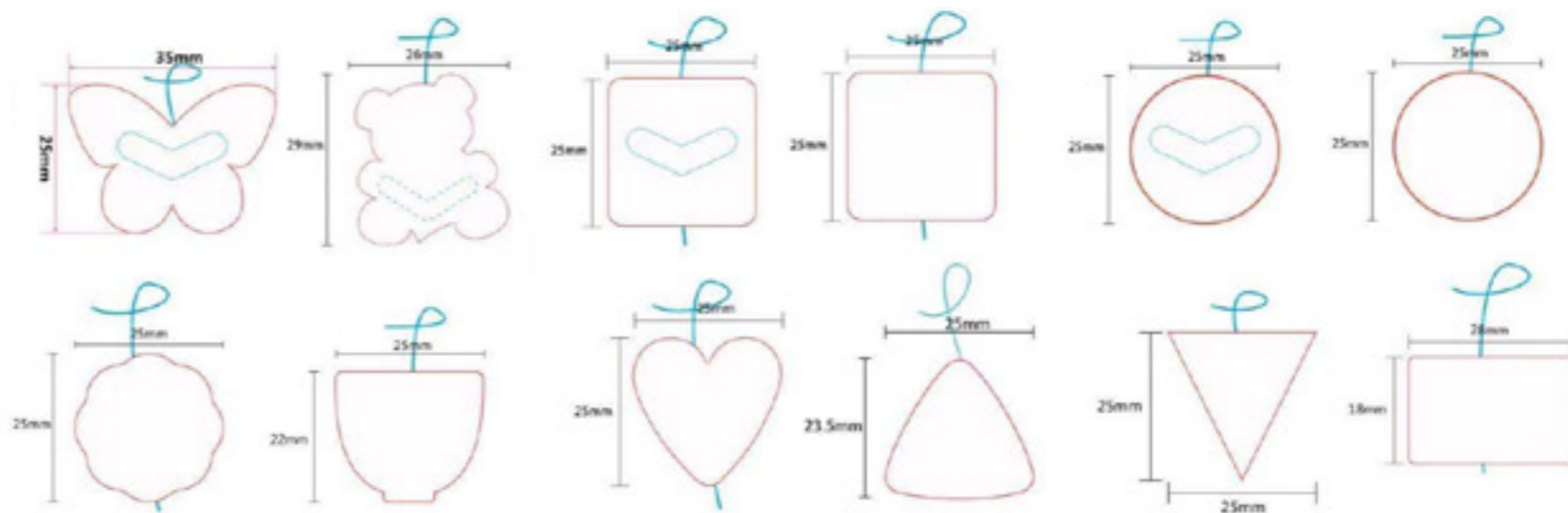

# Packing material

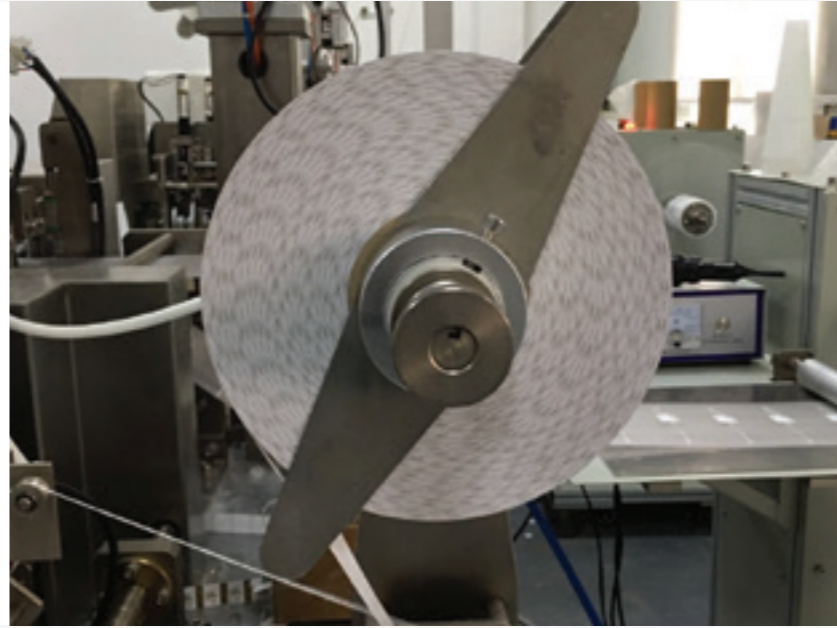
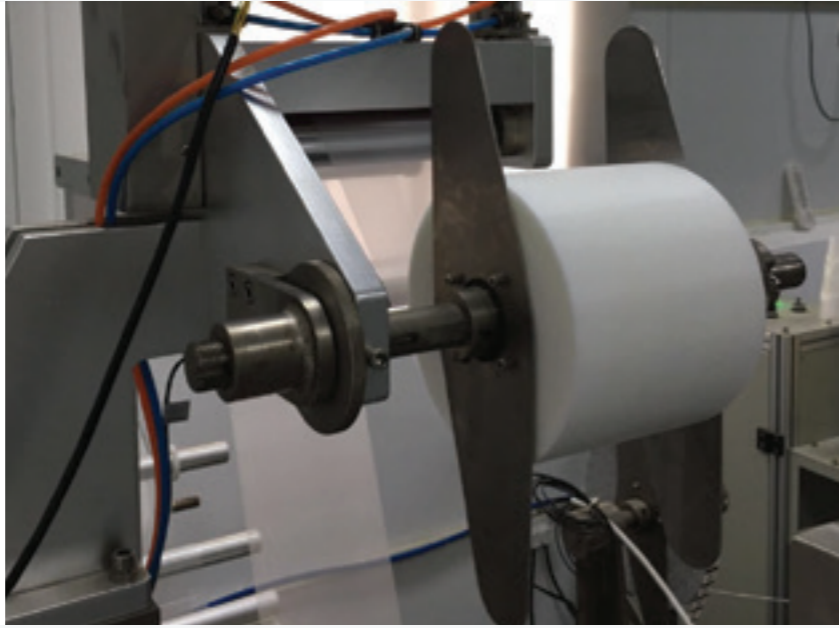
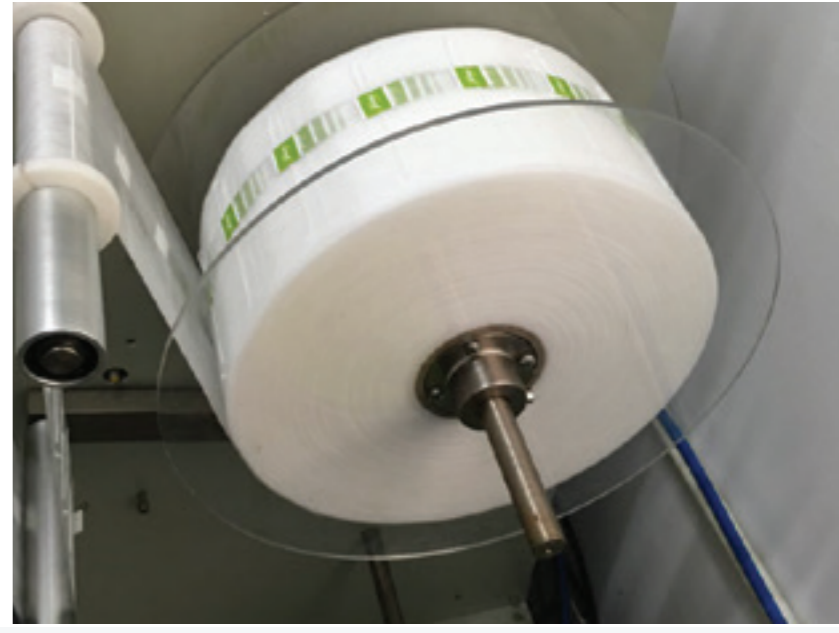

# Heat sealing material

We supply the traditional heat sealing material like PET/PE, BOPP/PE.

At the same time, we supply biodegradable heat sealing material such as PLA, PLA/paper with and without print.



Printing machine.



Heat sealing material.



# Other products

We produce a large range of other machines as well, such as envelope machines, powder and liquid packaging machines, tagging machines, and more.



## Pyramid Tea Bag Machine TP-P60

Suitable for packaging all kinds of flower tea, fruit tea, herbal tea.

## Envelope Packing Machine TP-E100

Suitable for packaging envelope bag for pyramid tea bag.



## Automatic Granule Packing Machine DXDK-40

This machine can be used to pack non-sticky granule raw materials such as tea, sugar, salt, coffee or seeds etc.



...and more.



Contact us  
for more details.

# Certificates

管理体系认证证书  
MANAGEMENT SYSTEM CERTIFICATE

ISO



TUV



CE



# After-sale service



## Warranty

Two years from the date of shipment.

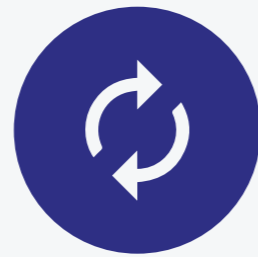

## Updates

Remote update (options).



## 24/7 Help

24 hours online services provide technical support.



## Free Training

One free technical training and Installation service.



## Life-long support

Life-long technical support accessories service.





Contact us ←

# **A7** GROUP

WhatsApp\Viber\Telegram  
**+7 910 729 73 63**

**Tecpacking<sup>®</sup>**